

Safety Valves

Type 06120, Type 06121



**Safety Valves, angle type, cast iron
type tested, TÜV-SV.577. S/G/L**

Standard safety valve
metal to metal seated, with lifting device
Flanged connection acc. to DIN EN 1092-1 PN16

Part No. 06120.X.0000

open bonnet

Part No. 06121.X.0000

closed bonnet

Available options - on request only:

- Disc with soft sealing
- Extended pressure and temperature ranges



Applications:

Provided as safety device for protection against excessive pressure in pressure vessels.

Approved for gases, vapours and fluids.

Working temperatures: -10°C / +14°F (263K) up to +200°C / +392°F (473K)

Materials	DIN EN	ASME/ASTM
1 Body	0.6025	A 48-83 Gr. 35B
2 Disc	1.4122	no reference
3 Stem	1.4021	A 276 Grade 420
4 Spring	1.1200	A 227
5 Bonnet	0.7040	A 536-87 Gr. 60-40-18
6 Lifting device	0.7040	A 536-87 Gr. 60-40-18

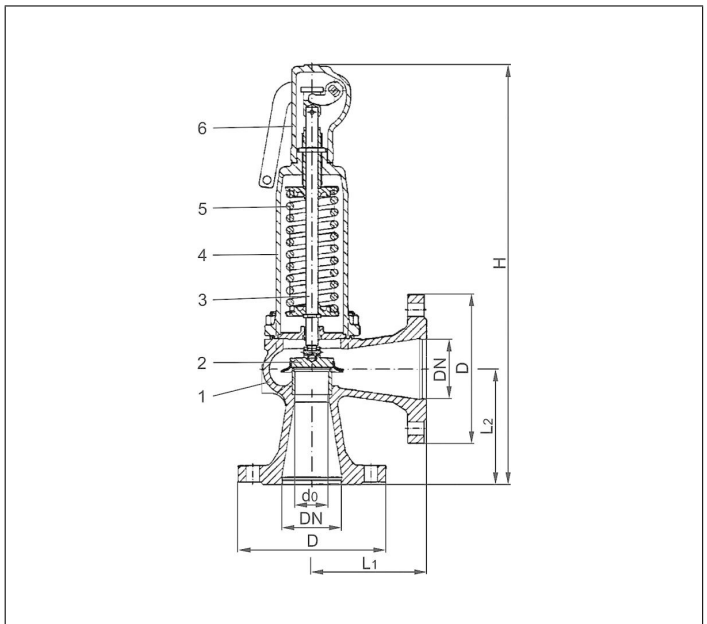

Essential: Valves are delivered at a set pressure, therefore when ordering please confirm set pressure, medium and temperature.

Standard marking acc. to Pressure Equipment Directive 2014/68/EU (PED).



Type 06120, 06121	Technical data									
Nominal size	DN	15	20	25	32	40	50	65	80	100
Orifice	d ₀	12	18	18	18	23	29	37	46	60
Dimension code	.X.	0150	0200	0250	0320	0400	0500	0650	0800	1000
Set pressure range	bar	0.2-16	0.2-16	0.2-16	0.2-16	0.2-16	0.2-16	0.2-16	0.2-16	0.2-16
Flange diameter	D	95	105	115	140	150	165	185	200	220
Height Type 06120	H	310	315	320	325	335	360	470	525	605
Height Type 06121	H	305	310	315	320	330	355	475	530	590
Length	L ₁	90	95	100	105	115	125	145	155	175
Length	L ₂	90	95	100	105	115	125	145	155	175
Weight	ca. kg	5.0	6.0	6.0	8.0	9.0	12.0	15.0	20.0	33.0
Coeff. of discharge gases, vapours	α _w	0.29	0.29	0.38	0.38	0.38	0.38	0.38	0.38	0.38
Coeff. of discharge fluids	α _w	0.19	0.19	0.25	0.25	0.25	0.25	0.25	0.25	0.25

Dimensions in mm.

Safety Valves

Type 06120, Type 06121



Discharge capacities

Calculation of flow rate acc. to AD2000-Merkblatt A2

Medium:

A = Saturated steam in kg/h

B = Air in m³/h at 0°C and 1013.25 mbar

C = Water in kg/h at 20°C

The capacity indicated below is for a fully opened valve.

d₀ - orifice

A₀ - flow area

Set pressure in bar (g)	DN	15			20			25 & 32			40		
	d ₀ (mm)	12			18			18			23		
	A ₀ (mm ²)	113.1			254.5			254.5			415.5		
	Medium	A	B	C	A	B	C	A	B	C	A	B	C
0.2	-	-	-	-	-	-	34	39	1770	55	63	2890	
0.5	15	18	846	30	35	1900	63	74	2510	102	120	4090	
1.0	31	37	1146	67	80	2580	101	121	3390	165	197	5540	
2.0	57	69	1621	129	156	3650	170	206	4800	278	336	7840	
3.0	77	95	1985	177	217	4470	232	284	5880	379	463	9600	
4.0	98	120	2292	221	272	5160	290	356	6790	473	582	11100	
5.0	117	145	2563	265	327	5770	347	429	7590	566	700	12400	
6.0	136	170	2807	308	382	6320	404	501	8310	659	818	13600	
7.0	155	194	3032	350	438	6820	459	574	8980	750	936	14700	
8.0	175	219	3242	394	493	7300	516	646	9600	842	1055	15700	
9.0	194	243	3439	437	548	7740	572	718	10200	934	1173	16600	
10.0	213	268	3625	480	604	8160	629	791	10700	1026	1291	17500	
12.0	251	317	3971	566	714	8930	741	936	11800	1210	1528	19200	
14.0	289	366	4289	650	825	9650	852	1081	12700	1391	1764	20700	
16.0	327	415	4585	736	935	10300	964	1225	13600	1574	2001	22200	

Set pressure in bar (g)	DN	50			65			80			100		
	d ₀ (mm)	29			37			46			60		
	A ₀ (mm ²)	660.6			1075.3			1662.1			2827.8		
	Medium	A	B	C	A	B	C	A	B	C	A	B	C
0.2	88	101	4600	142	165	7500	220	255	11600	375	431	19700	
0.5	163	191	6510	265	311	10600	410	481	16400	697	819	27800	
1.0	263	313	8810	428	510	14300	661	788	22200	1125	1341	37700	
2.0	442	534	12500	720	870	20300	1113	1344	31300	1893	2287	53300	
3.0	603	737	15300	981	1199	24800	1517	1854	38400	2581	3153	65300	
4.0	752	925	17600	1224	1505	28700	1892	2327	44300	3218	3958	75400	
5.0	900	1113	19700	1465	1811	32100	2265	2800	49600	3853	4763	84300	
6.0	1048	1301	21600	1706	2117	35100	2636	3273	54300	4485	5568	92400	
7.0	1192	1489	23300	1940	2423	37900	2999	3746	58600	5102	6373	99800	
8.0	1339	1677	24900	2179	2729	40600	3368	4219	62700	5730	7177	107000	
9.0	1485	1865	26400	2418	3035	43000	3737	4692	66500	6358	7982	113000	
10.0	1632	2053	27900	2656	3342	45300	4105	5165	70100	6984	8787	119000	
12.0	1924	2429	30500	3132	3954	49700	4842	6111	76800	8237	10397	131000	
14.0	2211	2805	33000	3599	4566	53700	5563	7057	82900	9464	12006	141000	
16.0	2503	3181	35200	4074	5178	57400	6297	8003	88700	10714	13616	151000	